



CAR FILLING



FUEL MANAGEMENT SYSTEMS



KITS



PUMPS



METERS



METERED NOZZLES

EDGARD

FEATURES

- MOBILE TROLLEY
- COMPATIBLE WITH CARS AND COMMERCIAL VEHICLES
- STURDY AND FUNCTIONAL
- SB325_X CAR NOZZLE
- SIMPLE AND INTUITIVE CONTROL PANEL

Born from PIUSI experience into the AdBlue® refilling equipment, EDGARD is a mobile system, battery powered, expressly engineered to dispense AdBlue® into cars and commercial vehicles.

Practical and movable, it is specifically designed for all the service stations that need a handy equipment for a guaranteed sale of AdBlue® by volume.

PERFORMANCE

5-12 L/MIN

FLOW RATE

**100-240V
50/60HZ**

VOLTAGE

19 MM

NOZZLE SPOUT

2 MT

LENGHT DELIVERY HOSE



EDGARD



PACKAGING

CODE	WEIGHT		PACKAGING			
	KG	LBS	MM	INCH	PCS/PALLET	PCS/BOX
FO0100EOA	40		1200X800X960		1	-



NOZZLES



FILTRATION



TANK MONITORING



HOSE REEL



ACCESSORIES



MERCHANDISE



AIR



ANTIFREEZE



AdBlue®



BIODIESEL



DIESEL



FOOD



GASOLINE



GREASE



KEROSENE



OIL



WATER



WINDSCREEN

FUNCTIONING



IN THE BOX

- MOBILE TROLLEY WITH SUZZARABLU PUMP DC
- SUCTION/DELIVERY HOSE
- SB325_X CAR NOZZLE
- INSTRUCTION MANUAL

DETAILS



SB325_X METER CAR



CONTROL PANEL



SUZZARABLU PUMP DC

DIMENSIONS

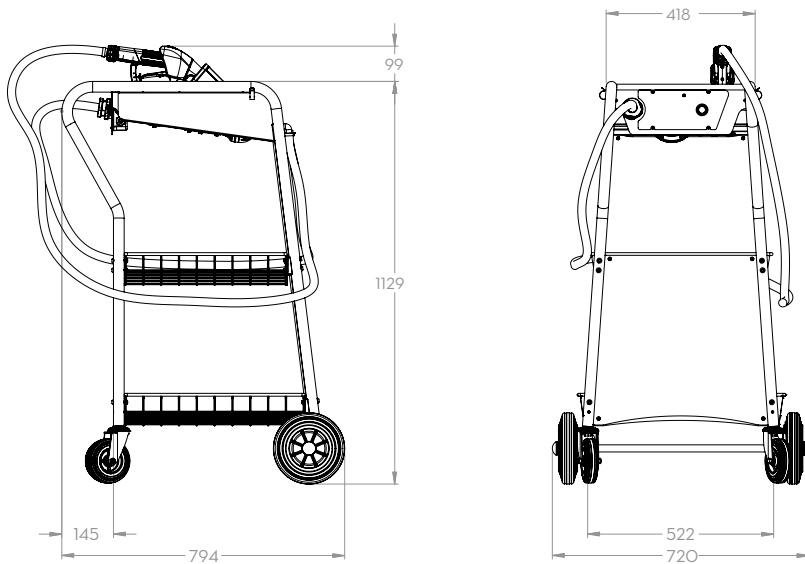

Dimensions expressed in millimeters

MATERIALS

- PUMP:
SUZZARABLU PUMP DC
- NOZZLE:
SB325_X CAR

TECHNICAL DATA

CODE	DESCRIPTION	FLUIDS TYPE	FLOW RATE		VOLTAGE		HOSE			START/STOP
			L/MIN	GPM	AC V/HZ DC VOLT	AMP. MAX.	LENGHT DELIVERY	SUCTION	Ø	
FO0100EOA	EDGARD		5-12	1,3 -3,1	100-240V 50/60HZ	1.2A - 230V / 2.2A - 115V	2M	1,5M	16MM	Si