



CAR FILLING



FUEL MANAGEMENT SYSTEMS



KITS



PUMPS



METERS



METERED NOZZLES

MCBOX B.SMART

FEATURES

- IDEAL FOR EXISTING PLANTS
- SUITABLE FOR ANY PUMP
- PULSE METER INPUT
- NATIVE WITH B.SMART CLOUD SOFTWARE

MCBOX B.SMART is the new advanced model of the MCBOX AdBlue® control system (electronic control panel that allows you to control any type of AC/DC pump, pulser litre-counter, nozzle and fuel level switches) integrated with the new fuel management and monitoring system PIUSI B.SMART. PIUSI MCBOX B.SMART is suitable for different applications and sectors including agriculture, automotive, logistics, and industry.

PERFORMANCE

VOLTAGE

AC/DC

POWER

UP TO

500

STORABLE

TRANSACTIONS



MCBOX B.SMART



PACKAGING

| CODE | WEIGHT | | PACKAGING | | |
|-----------|--------|------|-------------|---------------|---------|
| | KG | LBS | MM | INCH | PCS/BOX |
| FO0599000 | 5,2 | 11,5 | 300X300X180 | 11.8X11.8X7.1 | 1 |
| FO0599200 | 5,4 | 11,8 | 300X300X180 | 11.8X11.8X7.1 | 1 |
| FO0599150 | 5,4 | 11,8 | 300X300X180 | 11.8X11.8X7.1 | 1 |



NOZZLES



FILTRATION



TANK MONITORING



HOSE REEL



ACCESSORIES



MERCHANDISE



AIR



ANTIFREEZE



AdBlue®



BIODIESEL



DIESEL



FOOD



GASOLINE



GREASE



KEROSENE



OIL



WATER



WINDSCREEN

CONNECTION SCHEME



SUZZARABLU PUMP AC



K24 PULSE METER



OCIO



NOZZLE SWITCH WITH SB325_X



DIMENSIONS

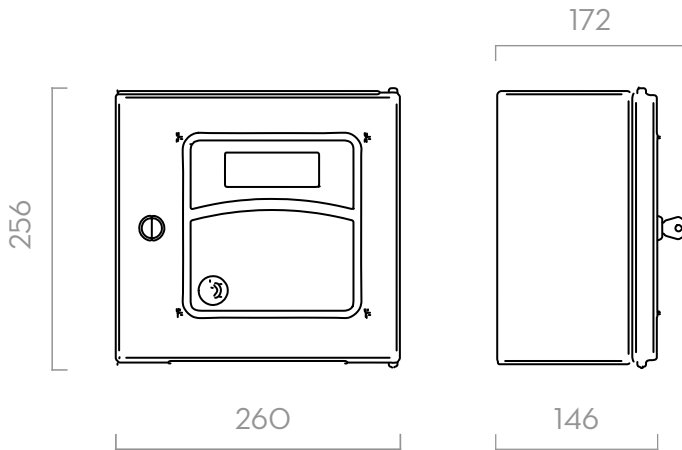

Dimensions expressed in millimeters

IN THE BOX

- MCBOX B.SMART
- DRIVER ACCESS ADD-ON
- INSTRUCTION MANUAL

DETAILS



EASY ACCESS TO CONNECTION



OCIO 2.0 ON REQUEST



B.SMART CLOUD SOFTWARE



B.SMART MOBILE APP

TECHNICAL DATA

| CODE | DESCRIPTION | FLUIDS TYPE | VOLTAGE | | | | B.SMART CLOUD SOFTWARE/APP |
|-----------|------------------------------------|------------------------|-----------------------|-----------------------|---------------|---------------------------|----------------------------|
| | | | AC VOLT/HZ DC VOLT | AC VOLT/HZ DC VOLT | POWER WATT | AMP. MAX. (load motor) | |
| FO0599000 | MCBOX 100-240V B.SMART 10 ACCESS | A Ad B D F G G K O W W | 100V-240V | | 5 W | 15 A | INCLUDED |
| FO0599200 | MCBOX B.SMART 2 PUMPS - 10 DRIVERS | A Ad B D F G G K O W W | 230/50 | - | 5 W | 15A | INCLUDED |
| FO0599150 | MCBOX B.SMART 12V/24V - 10 DRIVERS | A Ad B D F G G K O W W | - | 12/24 V | 5 W | 50/25 | INCLUDED |