



CAR FILLING



FUEL MANAGEMENT SYSTEMS



KITS



PUMPS



METERS



METERED NOZZLES

MP 180

FEATURES

- IN/OUT INTERCHANGEABLE
- LONG LIFE DIAPHRAGM
- BUILT-IN DIFFUSER
- SUITABLE FOR SUBMERSIBLE INSTALLATIONS
- MULTI-PURPOSE PUMP
- STURDY DESIGN

The PIUSI MP 180 is a long-lasting pneumatic diaphragm pump suitable for an heavy duty usage. Thanks to its characteristics, this multi-purpose pump allows a range of wide installations including potentially explosive conditions.

PERFORMANCE

UP TO

150 L/MIN

FLOW RATE

MAX CAPACITY

5M

SELF PRIMING

MAX

7 BAR

AIR SUPPLY
PRESSURE

MAX

Ø 4MM

PASSING SOLID



MP 180



PACKAGING

CODE	WEIGHT		PACKAGING		
	KG	LBS	MM	INCH	PCS/BOX
FOO208P30	7,5	16,5	270X390X400	10,6X15,4X15,7	1



NOZZLES



FILTRATION



TANK MONITORING



HOSE REEL



ACCESSORIES



MERCHANDISE



AIR



ANTIFREEZE



AdBlue®



BIODIESEL



DIESEL



FOOD



GASOLINE



GREASE



KEROSENE



OIL



WATER



WINDSCREEN

CHART

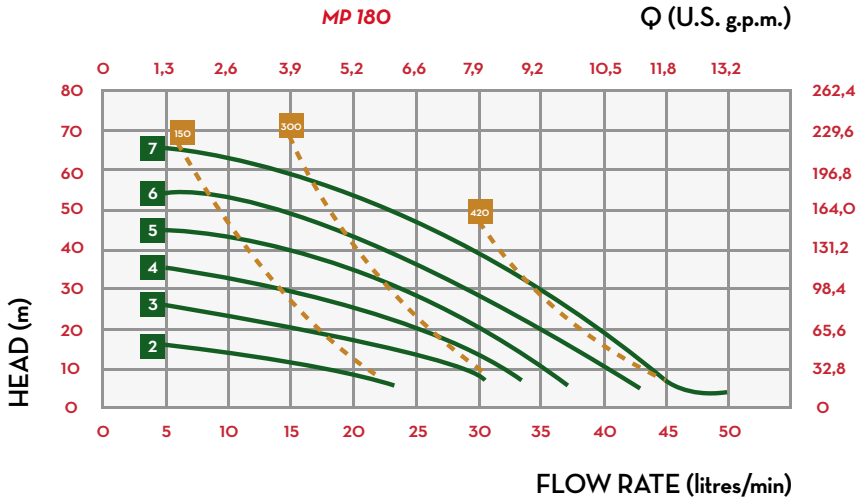

IN THE BOX

- MP 180 PUMP
- INSTRUCTION MANUAL

DETAILS



HEAVY DUTY MATERIALS



TECHNOPOLYMER BODY



STURDY DESIGN

DIMENSIONS

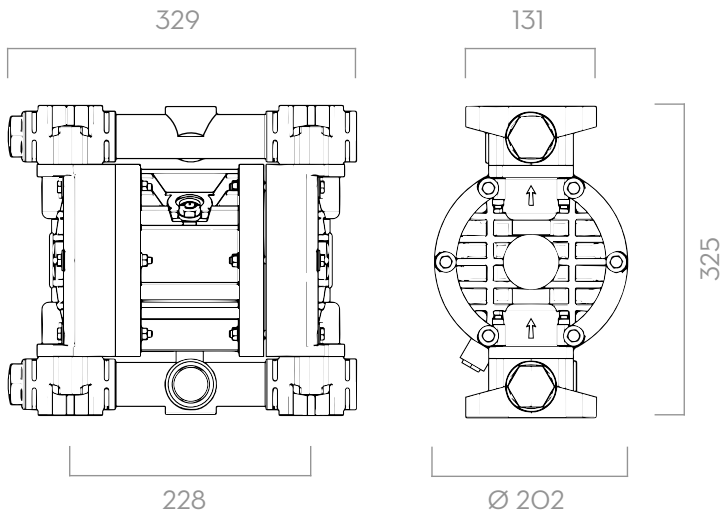

Dimensions expressed in millimeters

MATERIALS

- BODY: TECHNOPOLYMER
- SIDE PARTS AND COLLECTORS: POLYPROPYLENE
- DIAPHRAGM: EPDM

TECHNICAL DATA

CODE	DESCRIPTION	FLUIDS TYPE	PUMP BODY	IN / OUT	FLOW RATE	MEMBRANE TYPE	DIAPHRAGM AIR SIDE / FLUID SIDE	BALLS	BALL SEATS*	O-RING*	INTAKE / DELIVERY CONNECTION	AIR CONNECTION	MAX SELF-PRIMING CAPACITY	MAX HEAD**	MAX AIR SUPPLY PRESSURE	MAX Ø OF PASSING SOLID
					L/MIN								M	M	BAR	MM
FOO208P30	PIUSI MP 180		POLYPROPYLENE	1" G	150	DOUBLE	PTFE / HYTREL	PTFE	POLYPROPYLENE	PTFE	G 1" F	G 3/8" F	5	70	7	4

(*) ON REQUEST WE CAN PROVIDE MEMBRANES, BALLS, BALL SEATS AND O-RINGS IN DIFFERENT MATERIALS.
 (**) THE VALUE DEPENDS ON THE CONFIGURATION OF THE PUMP