



CAR FILLING



FUEL MANAGEMENT SYSTEMS



KITS



PUMPS



METERS



METERED NOZZLES

PIUSIBOX CAR SUCTION

FEATURES

- IDEAL TO EMPTY VEHICLE TANKS
- IT AVOIDS THE TANK OVERFILLING
- SUZZARABLU DIAPHRAGM PUMP
- EASY TO HANDLE

The PIUSI BOX CAR SUCTION is the perfect solution for those who need to drain an AdBlue® vehicle tank before servicing. It comes with a portable box that contains all the required equipment.

PERFORMANCE

UP TO

34 L/MIN

FLOW RATE

AC
VOLTAGE
POWER

MAX

2M

BOUND

HOSE LENGTH



PIUSIBOX CAR SUCTION



PACKAGING

CODE	WEIGHT		PACKAGING		
	KG	LBS	MM	INCH	PCS/BOX
FOO201R20	11,5	25,3	650X400X450	25,6X15,7X17,7	1



NOZZLES



FILTRATION



TANK MONITORING



HOSE REEL



ACCESSORIES



MERCHANDISE

INDEX



AIR



ANTIFREEZE



AdBlue®



BIODIESEL



DIESEL



FOOD



GASOLINE



GREASE



KEROSENE



OIL



WATER



WINDSCREEN

FUNCTIONING

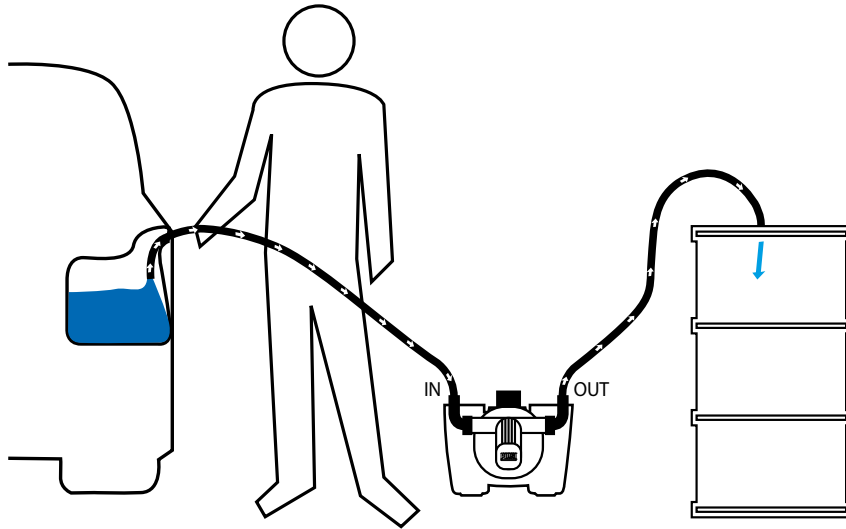

IN THE BOX

- SUZZARBLUE PUMP
- SUCTION/DELIVERY HOSE
- INSTRUCTION MANUAL

DETAILS



ON/OFF SWITCH



SUZZARBLUE PUMP AC



HANDLE

DIMENSIONS

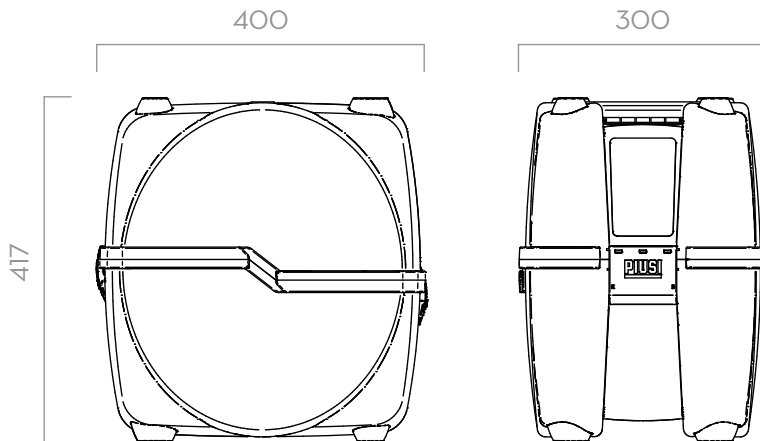

Dimensions expressed in millimeters

MATERIALS

- PUMP:
BODY: POLIPROPYLENE
DIAPHRAGM: POLIPROPYLENE

TECHNICAL DATA

CODE	DESCRIPTION	FLUIDS TYPE	FLOW RATE		VOLTAGE			RPM	DUTY CYCLE		CABLE	SUCTION HOSE 12 MM Ø	DELIVERY HOSE 12 MM Ø
			L/MIN	GPM	AC V/4Z DC VOLT	POWER WATT	AMP. MAX.		RPM	MIN		LENGHT (M)	LENGHT (M)
FO0201R20	PIUSIBOX CAR SUCTION ADBLUE		34	9	230/50	400	1,95	1450	20	YES	2	2	

PIUSIBOX CAR SUCTION

FILLING SYSTEMS