



SELF SERVICE MC 2.0

FEATURES

- STURDY STRUCTURE
- ALL-IN-ONE DISPENSER
- BUILT-IN LAN ADAPTER
- FRONT DOOR FOR EASY MAINTENANCE
- SSM 2.0 SOFTWARE REQUIRED
- IP55
- IDEAL FOR FUEL MANAGEMENT

The PIUSI SELF SERVICE MC 2.0 is a non-commercial fuel diesel dispenser able to fit any fleet management requirement. It requires the SSM 2.0 software to work. Equipped with 90 l/min continuous duty pump, it is suitable for any fleet dimension.

PERFORMANCE

UP TO 90 L/MIN	AC CONTINUOUS DUTY
FLOW RATE	VOLTAGE
± 0,5%	UP TO 1000
ACCURACY	USERS



ELECTRONIC METER INTEGRATED



SELF SERVICE MC 2.0

PACKAGING

CODE	WEIGHT		PACKAGING			N. BOXES / EUROPALLET	
	KG	LBS	MM	INCH	PCS/BOX	✈	🚚

COLUMN VERSION

FO074302B	75	165	1478X488X400	-	1	6	4
-----------	----	-----	--------------	---	---	---	---



FILTRATION



TANK MONITORING



HOSE REEL



ACCESSORIES



MERCHANDISE

PIUSI

BIS

ANY BIODIESEL

A

AIR

A

ANTIFREEZE

Ad

AdBlue®

B

BIODIESEL

D

DIESEL

F

FOOD

G

GASOLINE

G

GREASE

K

KEROSENE

O

OIL

W

WATER

W

WINDSCREEN

CHART

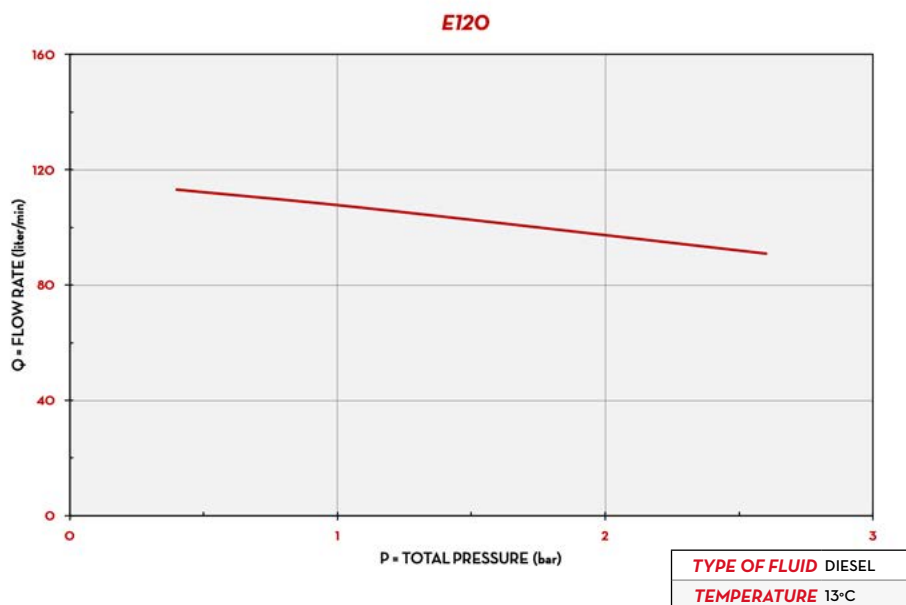

DIMENSIONS

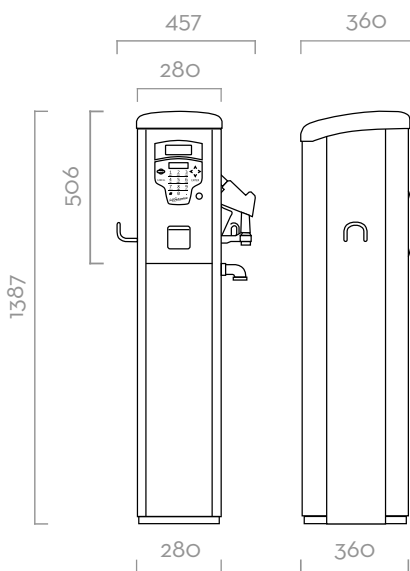

Dimensions expressed in millimeters

IN THE BOX

- SELF SERVICE MC 2.0 DISPENSER
- DELIVERY HOSE
- AUTOMATIC NOZZLE
- INSTRUCTION MANUAL

DETAILS



WATER CAPTOR FILTER



DRIVER&VEHICLE KEY (n.i.)



SSM 2.0 SOFTWARE



DATA TRANSFER SSM2.0

MATERIALS

- **PUMPS:**
E80 / E120
- **METER:**
K600/3
- **NOZZLE:**
AUTOMATIC NOZZLE
- **FILTER:**
WATER CAPTOR

TECHNICAL DATA

CODE	DESCRIPTION	FLUIDS TYPE	FLOW RATE		VOLTAGE			PUMP	METER	NOZZLE	FILTER		INLET	HOSE LENGTH METERS	SELF SERVICE MANAGEMENT 2.0
			L/MIN	GPM	AC V/HZ DC VOLT	POWER WATT	AMP. MAX.				H2O FILTER	FILTERING CAPACITY			

COLUMN VERSIONS

FO074302B	SELF SERVICE 100 MC 2.0	D	90	24	230/50	1150	5,7	E120	K600	A120	YES	30µ	1" 1/2	4	REQUIRED
-----------	-------------------------	----------	----	----	--------	------	-----	------	------	------	-----	-----	--------	---	----------