



FUEL MANAGEMENT SYSTEMS



DISPENSERS



KITS



PUMPS



METERS



NOZZLES

ST BOX

FEATURES

- STURDY STRUCTURE
- LOCKABLE AND SAFE
- READY TO USE
- FILTRATION GUARANTEED
- NOZZLE CONTACT (PRO VERSION ONLY)

The PIUSI ST BOX is a diesel refueling station complete with pump, flow meter and filter, with lockable metal protection box. The unit is complete with antistatic hose for diesel fuel and automatic dispensing nozzle. The PRO version features the electronic access control box (ACCESS 85).

PERFORMANCE

UP TO

90 L/MIN

FLOW RATE

AC

CONTINUOUS DUTY

POWER

± 1%

ACCURACY



PACKAGING

CODE	WEIGHT		PACKAGING		
	KG	LBS	MM	INCH	PCS/BOX
FO0365020	-	-	-	-	-
FO0365050	36	72	575X320X607	22,6X12,6X23,9	1
FO039900A	50	110	590X340X720	23,2X13,4X28,3	1
FO0365010	40	88	575X320X607	22,6X12,6X23,9	1
FO0365B40	40	88	575X320X607	22,6X12,6X23,9	1
FO0365B30	40	88	575X320X607	22,6X12,6X23,9	1



FILTRATION



TANK MONITORING



HOSE REEL



ACCESSORIES



MERCHANDISE

PIUSI



ANY BIODIESEL



AIR



ANTIFREEZE



AdBlue®



BIODIESEL



DIESEL



FOOD



GASOLINE



GREASE



KEROSENE



OIL



WATER



WINDSCREEN

CHART

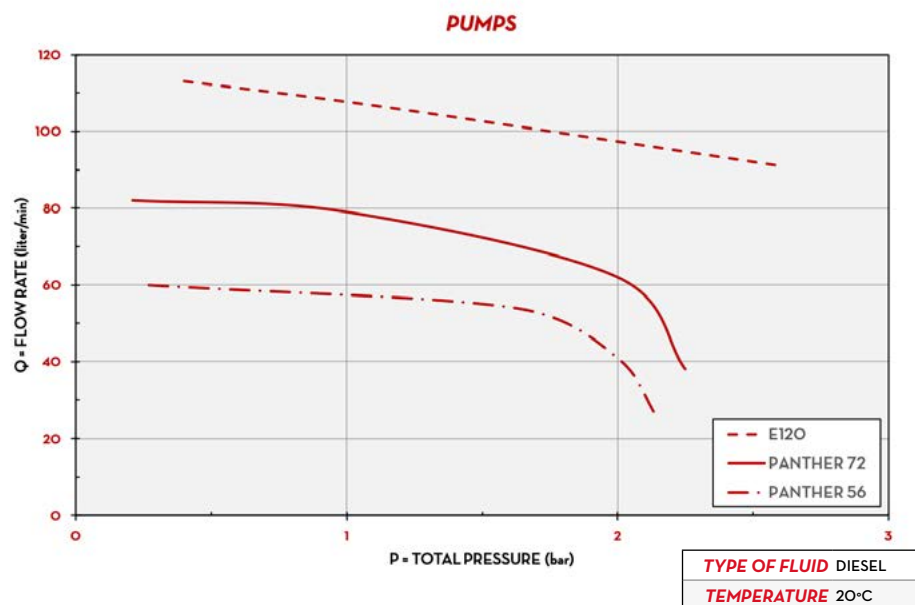

DIMENSIONS

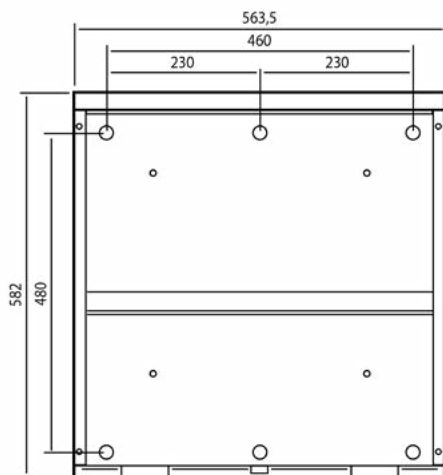

Dimensions expressed in millimeters

IN THE BOX

- ST BOX UNIT
- METER
- FILTER
- DELIVERY HOSE
- NOZZLE
- INSTRUCTION MANUAL

DETAILS



K33 MECH. METER



WATER CAPTOR FILTER

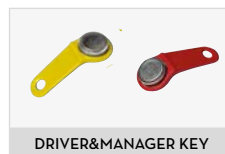

DRIVER&MANAGER KEY



ACCESS 85

COMPONENTS

- **PUMPS:**
PANTHER AC
E80/E120
BIPUMP
- **NOZZLE:**
AUTOMATIC NOZZLE
- **METER:**
K33
K24
- **FILTER**
WATER CAPTOR
- **ACCESS CONTROL**
ACCESS85

TECHNICAL DATA

CODE	DESCRIPTION	FLUIDS TYPE	FLOW RATE		VOLTAGE			PUMP	METER	NOZZLE	FILTER	HOSE		INLET
			L/MIN	GPM	AC V./HZ	DC VOLT	POWER WATT					AMP. MAX.	LENGTH	
FO0365020	ST BOX PANTHER 56 BASIC	D	56	15	230/50	350	3	PANTH. 56	K33	A60	YES	6M	1"	1"
FO0365050	ST BOX E 120 BASIC	D	90	22	230/50	750	5,7	E 120	K33	A120	YES	8M	1"	1"
FO039900A	ST BOX BIPUMP 12V K33 A120	D	80	21	12	530	44	BIPUMP	K33	A80	NO	4M	1"	1"
FO0365010	ST BOX PANTHER 72 PRO - ACCESS 85	D	70	19	230/50	500	4,2	PANTH.72	K33	A60	YES	8M	1"	1"
FO0365B40	ST BOX P72M K600 B/3 PULS A70 WC 6M B100	D, BIO	70	19	230/50	500	4,2	PANTH.72	K600	A70	YES	6M	1"	1"
FO0365B30	ST CASSETTA P72/M K33 A70 WC 6MT B100	D, BIO	70	19	230/50	500	4,2	PANTH.72	K33	A70	YES	6M	1"	1"

PRO VERSION ONLY